

47"  
57"  
60"

Let's rise to  
the occasion.

the lift-your-spirits

# Series L 2S Adjustable Height Single Desk

## ASSEMBLY INSTRUCTIONS

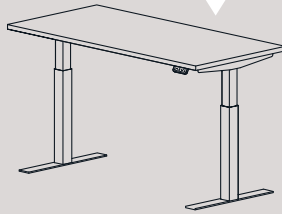

Included in the boxes:

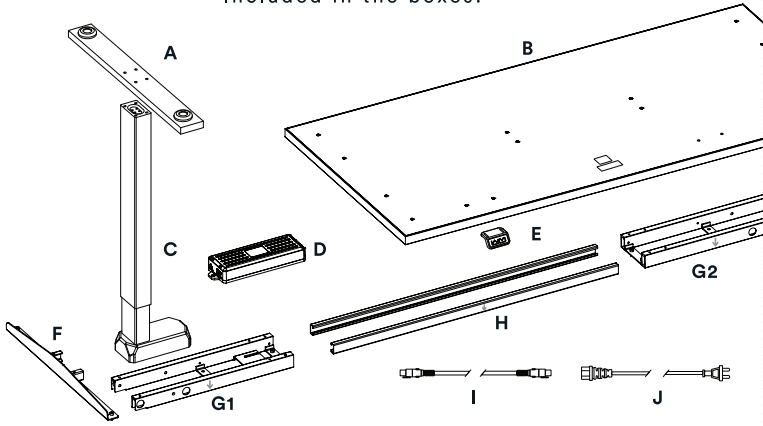

- A. Foot x2
- B. Desk Top x1
- C. Leg x2
- D. Control Box x1
- E. Control Handset x1
- F. Bracket x2

- G1. Leg Frame, Slotted x1
- G2. Leg Frame x1
- H. Spanning Rail x2
- I. Leg Jumper Cable x1
- J. Power Cable x1

### Tools needed:



### Screws included (actual size):

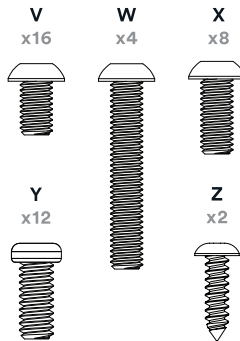

## INSTRUCTIONS FOR ASSEMBLY

1. Lay the desk top on a blanket and set aside.

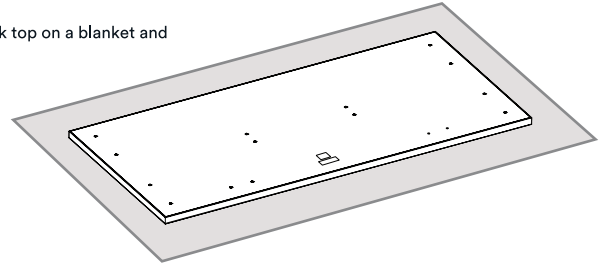

2. Lay out all leg structure parts. Be sure to disassemble the frame structure into two leg frames and two spanning rails. Set aside the control box.

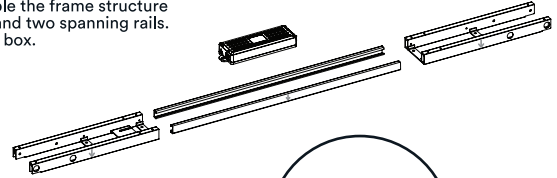

3. Align holes of leg frame G1 with either leg and attach all four screws. Ensure the proper orientation of leg frame G1 as illustrated.

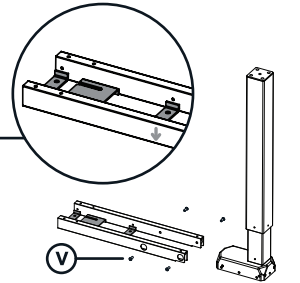

4. Slide the bracket onto leg frame section and attach both screws.

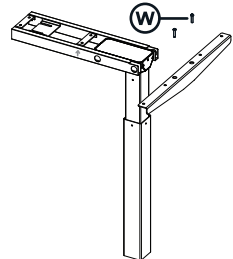

5. Attach foot to leg.

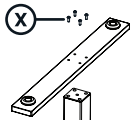

6. Repeat Steps 3, 4, and 5 using leg frame G2, leg, and bracket.

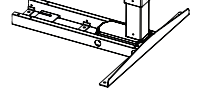

7. Slot the Spanning Rails between the opposing Leg Frame sections.

Ensure the Spanning Rails are oriented as directed by the arrow: outward and pointed toward the floor.

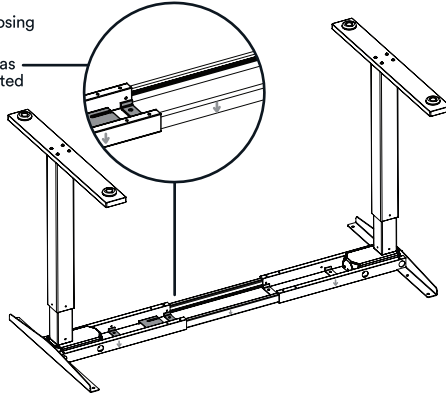

8. With a buddy's help, transfer entire leg frame structure to the desk top.

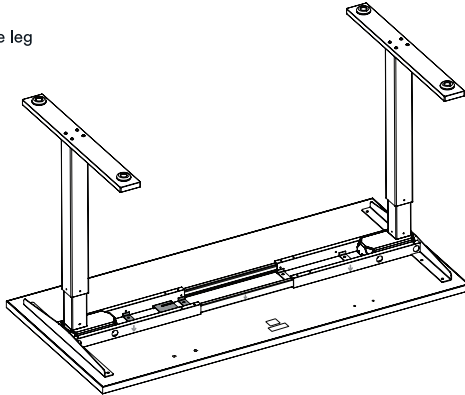

- 9a. Beginning at one end, align the bracket holes and leg frame holes with the pre-drilled holes on the desk top. Install 6 screws per leg.

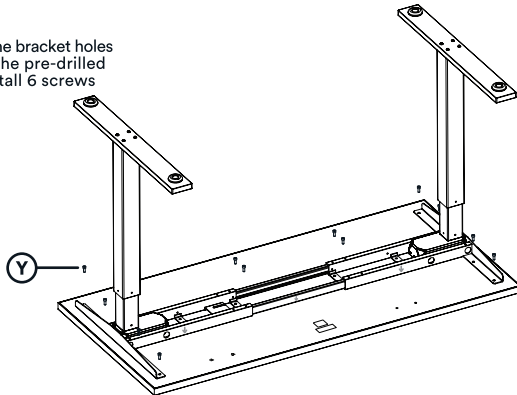

- 9b. Move to the opposing leg structure. Align and screw loosely to the desk top.

10. Shift the rail position as necessary to center the arrows.

Insert and tighten screws, pinning the spanning rails against the leg frame.

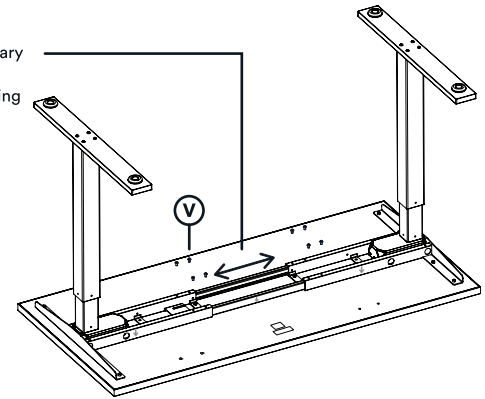

11. Slot the control box into leg frame G1.

Align the handset flush with the front edge of the desk top. Using a standard Phillips head screwdriver, drive the screws into place.

### HEADS UP!

Pilot holes are not necessary to perform this step.

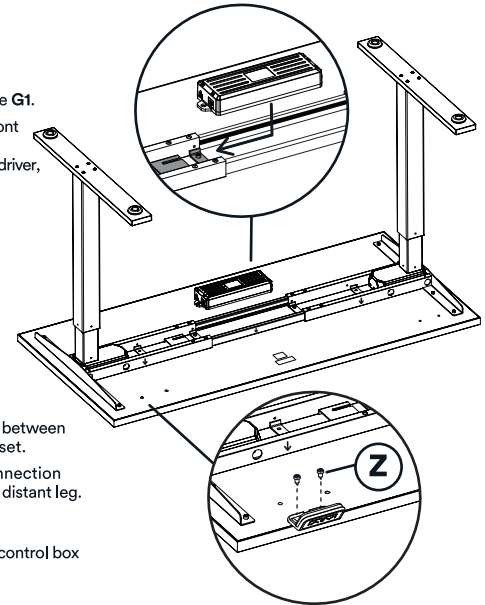

12. Complete the cable connections between the control box, legs, and handset.

Use cable I to complete the connection between the control box and the distant leg.



The handset cable plugs into the control box port marked "HS."

13. With your buddy, lift by the legs and rotate the desk upright. Move it to its intended spot and adjust the leveling glides, assuring that the desk surface is level (use the Level app on your smartphone).

14. Connect the power cord J to the control box and plug into the outlet.



15. Follow instructions to reset the control box and further customize desk settings.

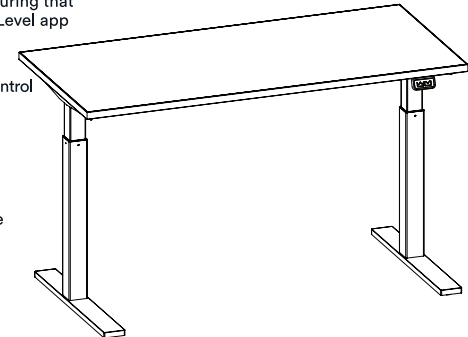

# INSTRUCTIONS FOR USE

## Take precautions

Failure to follow these recommendations could result in substandard product performance, property damage, and/or personal injury.

- Be aware of pinch hazards between the desk top edges and other objects.
- Keep objects out of the desk top's travel path: above, beside and under the desk, including your knees!
- Ensure the desk top remains at least 2" away from walls throughout the entire travel distance.
- Ensure all corded items used on the desk top have the cable length required to travel the entire range of motion.
- If the desk encounters resistance in its path, either up or down, it will rebound slightly and stop.
- Do not allow children to operate the desk unsupervised.
- Do not sit or stand on the desk top.
- Do not open the control box or the leg motor caps. Doing so voids the manufacturer's warranty and risks irreparable damage to the electronics and motor functions.
- The control box and motors have an operation cycle limit of 2 minutes on/18 minutes off. Use outside these norms can result in irreparable damage.
- This desk is meant for use in general office environments. All other use is at the user's own risk.
- Do not attempt to relocate the desk yourself. Grab a buddy for help!

## Reset the control box

The Control Box must be reset prior to use, after power failures, or other mechanical errors.

1. Remove all objects from under the desk.
2. Press and hold the **DOWN** arrow key until the desk reaches its lowest position (about 27.5"h).
3. Press and hold the **DOWN** arrow key one more time; the desk will fall and rise slightly. Release the key. The desk is ready for regular use.

## Perform basic functions

Press and hold the UP and DOWN arrow keys to raise and lower the desk top to the desired height.

## Upgrade your control handset

If you've purchased the control handset with memory settings, you can download instructions for use from our website: [poppin.com/assembly](http://poppin.com/assembly). Or, call us at 1-888-6-POPPIN or email us at [hi@poppin.com](mailto:hi@poppin.com) to request a copy.

---

Shop the complete furniture collection at [poppin.com](http://poppin.com)



Designed by Poppin in NYC

---

**Poppin, Inc.**  
16 Madison Square West  
New York, NY 10010

(888) 676-7746  
[hi@poppin.com](mailto:hi@poppin.com)  
[@workhappy @poppin](https://twitter.com/workhappy)

For patent or patent application  
information visit [poppin.com/patents](http://poppin.com/patents)

©Poppin 2020

v02\_Jul2020

the lift-your-spirits

# Series L 2S Adjustable Height Single Desk

## ASSEMBLY INSTRUCTIONS

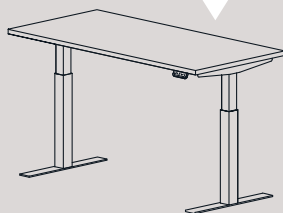

Included in the boxes:

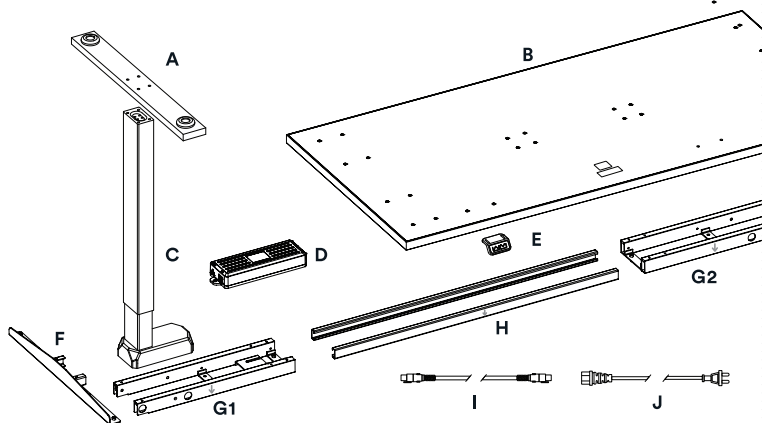

- A. Foot x2
- B. Desk Top x1
- C. Leg x2
- D. Control Box x1
- E. Control Handset x1
- F. Bracket x2

- G1. Leg Frame, Slotted x1
- G2. Leg Frame x1
- H. Spanning Rail x2
- I. Leg Jumper Cable x1
- J. Power Cable x1

### Tools needed:

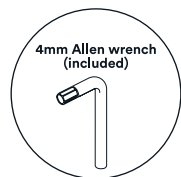

### Screws included (actual size):

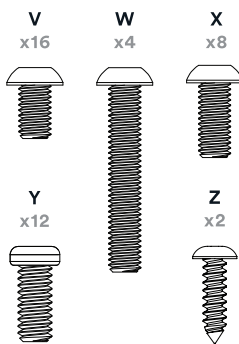

## INSTRUCTIONS FOR ASSEMBLY

1. Lay the desk top on a blanket and set aside.

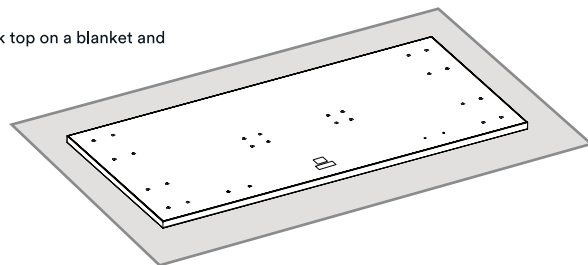

2. Lay out all leg structure parts. Be sure to disassemble the frame structure into two leg frames and two spanning rails. Set aside the control box.

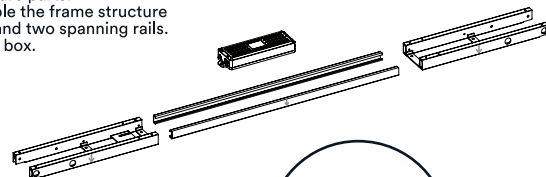

3. Align holes of leg frame G1 with either leg and attach all four screws. Ensure the proper orientation of leg frame G1 as illustrated.

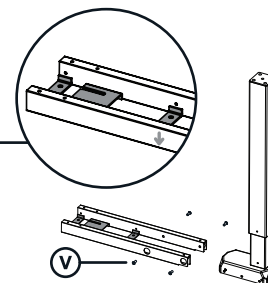

4. Slide the bracket onto leg frame section and attach both screws.

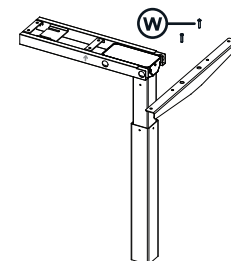

5. Attach foot to leg.

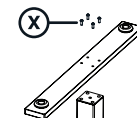

6. Repeat Steps 3, 4, and 5 using leg frame G2, leg, and bracket.

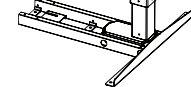

7. Slot the Spanning Rails between the opposing Leg Frame sections.

Ensure the Spanning Rails are oriented as directed by the arrow: outward and pointed toward the floor.

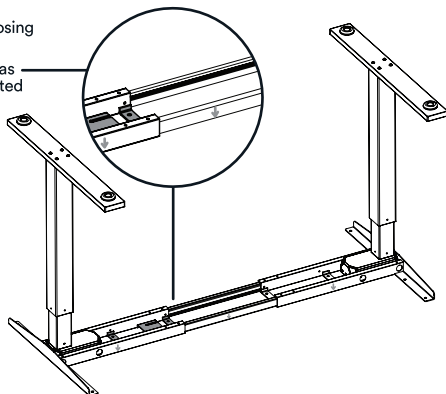

8. With a buddy's help, transfer entire leg frame structure to the desk top.

**HEADS UP!**  
Choose your preferred alignment:  
1. Desk assembly  
2. Table assembly

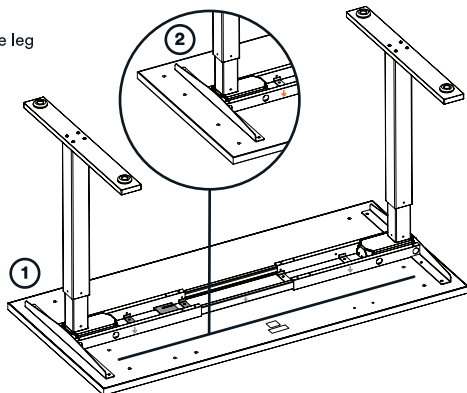

- 9a. Beginning at one end, align the bracket holes and leg frame holes with the pre-drilled holes on the desk top. Install 6 screws per leg.

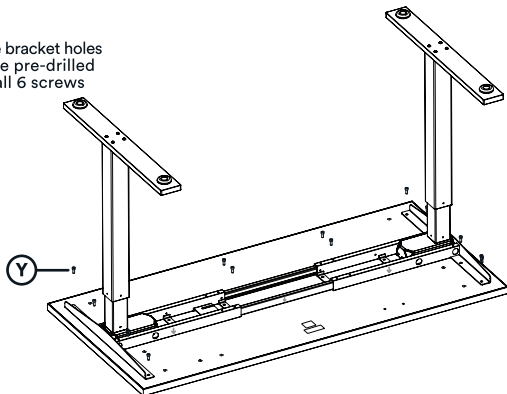

- 9b. Move to the opposing leg structure. Align and screw loosely to the desk top.

10. Shift the rail position as necessary to center the arrows.

Insert and tighten screws, pinning the spanning rails against the leg frame.

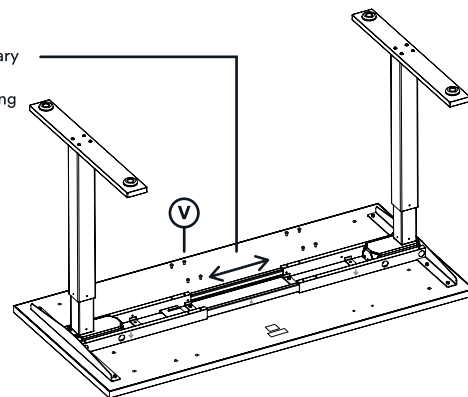

11. Slot the control box into leg frame G1.

Align the handset flush with the front edge of the desk top. Using a standard Phillips head screwdriver, drive the screws into place.

**HEADS UP!**  
Pilot holes are not necessary to perform this step.

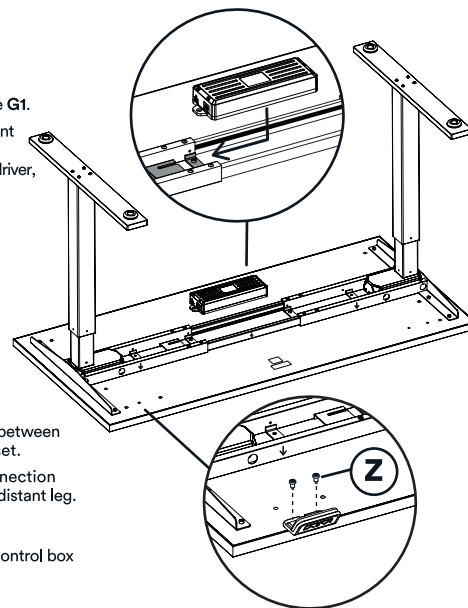

12. Complete the cable connections between the control box, legs, and handset.

Use cable I to complete the connection between the control box and the distant leg.



The handset cable plugs into the control box port marked "HS."

13. With your buddy, lift by the legs and rotate the desk upright. Move it to its intended spot and adjust the leveling glides, assuring that the desk surface is level (use the Level app on your smartphone).

14. Connect the power cord J to the control box and plug into the outlet.



15. Follow instructions to reset the control box and further customize desk settings.

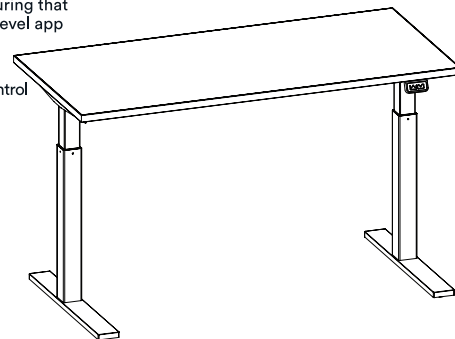

# INSTRUCTIONS FOR USE

## Take precautions

Failure to follow these recommendations could result in substandard product performance, property damage, and/or personal injury.

- Be aware of pinch hazards between the desk top edges and other objects.
- Keep objects out of the desk top's travel path: above, beside and under the desk, including your knees!
- Ensure the desk top remains at least 2" away from walls throughout the entire travel distance.
- Ensure all corded items used on the desk top have the cable length required to travel the entire range of motion.
- If the desk encounters resistance in its path, either up or down, it will rebound slightly and stop.
- Do not allow children to operate the desk unsupervised.
- Do not sit or stand on the desk top.
- Do not open the control box or the leg motor caps. Doing so voids the manufacturer's warranty and risks irreparable damage to the electronics and motor functions.
- The control box and motors have an operation cycle limit of 2 minutes on/18 minutes off. Use outside these norms can result in irreparable damage.
- This desk is meant for use in general office environments. All other use is at the user's own risk.
- Do not attempt to relocate the desk yourself. Grab a buddy for help!

## Reset the control box

The Control Box must be reset prior to use, after power failures, or other mechanical errors.

1. Remove all objects from under the desk.
2. Press and hold the **DOWN** arrow key until the desk reaches its lowest position (about 27.5"h).
3. Press and hold the **DOWN** arrow key one more time; the desk will fall and rise slightly. Release the key. The desk is ready for regular use.

## Perform basic functions

Press and hold the UP and DOWN arrow keys to raise and lower the desk top to the desired height.

## Upgrade your control handset

If you've purchased the control handset with memory settings, you can download instructions for use from our website: [poppin.com/assembly](http://poppin.com/assembly). Or, call us at 1-888-6-POPPIN or email us at [hi@poppin.com](mailto:hi@poppin.com) to request a copy.

---

Shop the complete furniture collection at [poppin.com](http://poppin.com)



Designed by Poppin in NYC

---

**Poppin, Inc.**  
16 Madison Square West  
New York, NY 10010

(888) 676-7746  
[hi@poppin.com](mailto:hi@poppin.com)  
[@workhappy @poppin](https://twitter.com/workhappy)

For patent or patent application  
information visit [poppin.com/patents](http://poppin.com/patents)

©Poppin 2020

v02\_Jul2020